

3M-Matic™ Automatic Adjustable Case Sealer 120af



3M™ AccuGlide™ Taping Head 2+ for low impact sealing that protects cases

Side drive belts for accurate sealing

Shown with optional accessories

Auto flap folding at up to 27 cases per minute

Traction-grip drive belts located on each side of the 3M-Matic™ Automatic Adjustable Case Sealer 120af center and stabilize boxes for consistently accurate top and bottom taping. Flaps are automatically folded and sealed for productivity of up to 27 cases per minute. Height and width can easily be adjusted for a wide range of RSCs.

Features include:

- Dual crossbars and 3-point mounting for taping head stability
- Gear motor drives for dependability with cases up to 65 pounds (29 kg)
- Top flap compression rollers to close flaps for an improved seal
- One centrally-located emergency stop on each side for quick and easy access

- Safety-interlocked hinged access door with steel screen for viewing case flow
- Designed for use with 36-48mm (1.5"-2") Scotch® Box Sealing Tapes; use 78mm (3") tape with optional taping head

Options: Lockable casters for easy movement, powered infeed conveyor, guard access door on both sides, low tape indicator, and tape application monitor

Box capacities

Length: 6" to 25"
(152mm to 635mm)

Width: 4.75" to 20"
(121mm to 508mm)

Height: 4.75" to 20"
(121mm to 508mm)

Weight: 4-65 lbs.
(2-29 kg)



Specifications

3M-Matic™ Automatic Adjustable Case Sealer 120af

120af Footprint

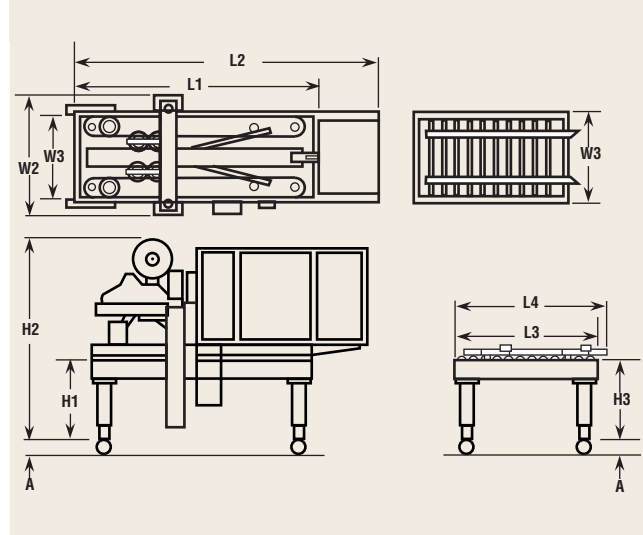
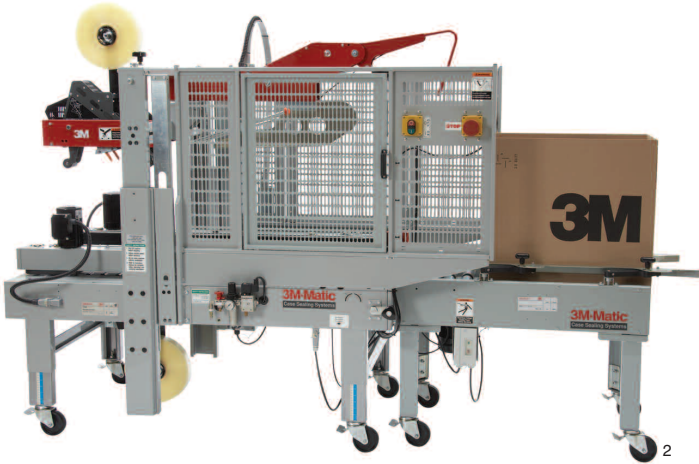

3

Machine	Tape Size Inches (mm)	Machine Weight* Lbs. (kg)	Machine Dimensions Inches (mm)											Electrical	Operating Rate at 75PSIG 11.5 SCFM	Drive Belt Speed
			A**	H1	H2	H3	W1	W2	W3	L1	L2	L3	L4			
			Min.	Max.	Min.	Max.	Min.	Max.	Min.	Max.	Min.	Max.				
120af	1.5-2 (36-48)	545 (248)	4.75 (121)	23 (584)	53.375 (1356)	23 (584)	30.125 (768)	35.375 (899)	22.5 (572)	60 (1524)	75.5 (1918)	37.5 (953)	37.5 (953)	115V 60Hz 2.8A 340 watts 8' cord	Up to 27 per minute	75 fpm (.4 m/s)
				28.125 (714)	74 (1880)	28.125 (714)							45.25 (1149)			

* Uncrated ** Optional casters

Use with clean dry boxes in dry, relatively clean environments at 40°F to 120°F (4.4°C to 48.9°C).

Machine	Box Capacities Inches (mm)			Weight Range Lbs. (kg)
	Length Min. Max.	Width Min. Max.	Height Min. Max.	
120af	6" to 25" (152mm to 635mm)	4.75" to 20" (121mm to 508mm)	4.75" to 20" (121mm to 508mm)	4-65 lbs. (2-29 kg)

Contact your 3M representative for special modifications that may be available for sizes not listed.

Note: This technical information and data should be considered representative or typical only and should not be used for specification purposes.

Note: The 3M-Matic™ Side Belt Adjustable Case Sealer 120af can accommodate most boxes within the size range listed here.

However, if:

Box Length in Direction of Seal
Box Height
is less than .75

Boxes should be test run to ensure proper machine performance.



4

Product Use: User is responsible for determining whether the product is fit for a particular purpose and suitable for user's method of application.

Warranty and Limited Remedy: THE FOLLOWING WARRANTIES ARE MADE IN LIEU OF ALL OTHER WARRANTIES, EXPRESS OR IMPLIED, INCLUDING, BUT NOT LIMITED TO THE IMPLIED WARRANTY OF MERCHANTABILITY, THE IMPLIED WARRANTY OF FITNESS FOR A PARTICULAR PURPOSE AND ANY IMPLIED WARRANTY ARISING OUT OF A COURSE OF DEALING, A CUSTOM OR USAGE OF TRADE: 3M sells its 3M-Matic™ Case Sealer 120af with the following warranties: 1) The Taping Head knife blades, springs and rollers will be free from all defects for ninety (90) days after delivery. 2) All other Taping Head parts will be free from all defects for three (3) years after delivery. 3) All other parts will be free from all defects for two (2) years after delivery. Please refer to individual data pages for additional details and exceptions. If any 3M-warranted part is proved to be defective within its warranty period, then the exclusive remedy and 3M's and seller's sole obligation shall be, at 3M's option, to repair or replace the part, provided the defective part is returned immediately to 3M's factory or an authorized service station designated by 3M. A part will be presumed to have become defective after its warranty period unless the part is received or 3M is notified of the problem no later than five (5) calendar days after the warranty period. If 3M is unable to repair or replace the part within a reasonable time, then 3M, at its option, will replace the equipment or refund the purchase price. 3M shall have no obligation to provide or pay for the labor required to install the repaired or replacement part. 3M shall have no obligation to repair or replace (1) those parts failing due to operator misuse, carelessness, or due to any accidental cause other than equipment failure, or (2) parts failing due to non-lubrication, inadequate cleaning, improper operating environment, improper utilities or operator error. **Limitation of Liability:** 3M and seller shall not be liable for direct indirect, special, incidental or consequential damages based upon breach of warranty, breach of contract, negligence, strict liability or any other legal theory. The foregoing Warranty and Limited Remedy and Limitation of Liability may be changed only by a written agreement signed by authorized officers of 3M and seller.



Industrial Adhesives and Tapes Division

Bldg. 21-1W-10
900 Bush Ave.
St. Paul, MN 55106
1-800-362-3550
www.3M.com/packaging

Idépack Verpakkingsmachines BV

Zeilmaker 8
NL-3861 SM Nijkerk
THE NETHERLANDS
Tel. +31(0)33 299 00 08
www.idepack.com
info@idepack.com

3M, 3M-Matic and AccuGlide are trademarks of 3M Company.

Scotch® is a registered trademark of 3M Company.

Printed in U.S.A.
© 3M 2008
70-0710-0371-2